

## MANCHON DE CENTRAGE

Code article: 01170

Matière: 1.7131 ≈ 60HRC  
Interchangeable avec E1170

M1170 - d3

d2	d3	L
9	14	11,5
11	16	13,5
13	20	15,5
16	26	17,5
18	30	19,5
22	36	19,5
26	42	19,5
32	54	19,5

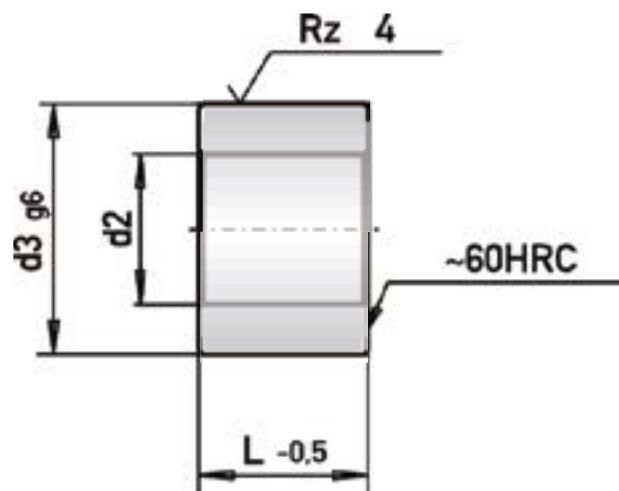

## BUTEE DE BATTERIE

Code article: 01500

Matière: 1.7131  
≈ E1500

M1500 - d - h

d1	M	d	h
4,3	4	18	3
5,3	5	20	4
4,3	4	28	3
5,3	5	30	4

